

MHXWFWCA

PARAPET MOUNTING BRACKET

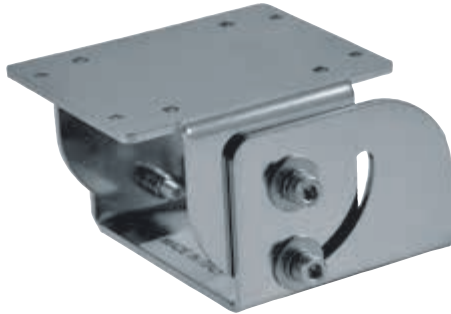

DESCRIPTION

Joint for the column mount of housings of MAXIMUS family. Made of AISI 316L stainless steel.

TECHNICAL DATA

MECHANICAL

Joint for housings: MVX, MVXT, MVXHD, MHX, MHXT, NXM, NXM36, NXM36 Hi-PoE, NXW, NTW, NTM

Suitable for: NXFWBT

Made of AISI 316L electropolished stainless steel

Load rating: 40kg (88lb)

Dimensions: \varnothing 101.6mm (4in)

Unit weight: 2kg (4.4lb)

PART NUMBER

MHXWFWCA AISI 316L stainless steel ball joint

PACKAGE

Model Number	Weight	Dimensions (WxHxL)	Master carton
MHXWFWCA	2.5kg (5.5lb)	19x19x19 cm (7.5x7.5x7.5in)	-

TECHNICAL DRAWINGS

The indicated measurements are expressed in millimetres.

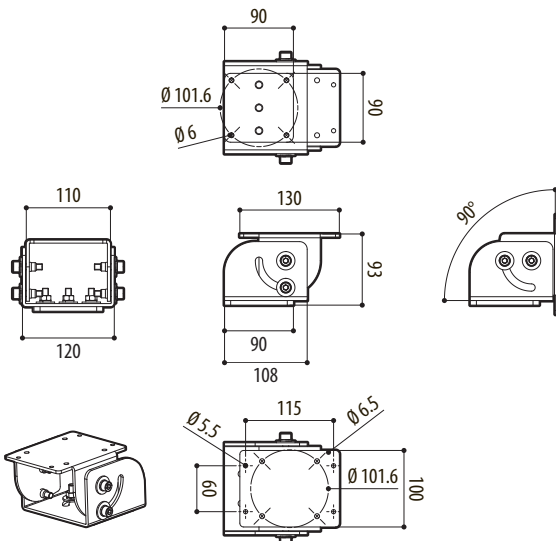

MHXWFWCA