

# WCM3A

CEILING MOUNT



## DESCRIPTION

Ceiling mount. It allows an easy position adjustment of the housing.

## TECHNICAL DATA

### MECHANICAL

Made of steel  
Adjustable joint  
Load rating: 15kg (33.5lb)  
Length: 300mm (11.8in)  
Unit weight: 1.8kg (4lb)

## PART NUMBER

WCM3A Ceiling bracket with ball joint

## PACKAGE

Model Number	Weight	Dimensions (WxHxL)	Master carton
WCM3A	2.1kg (4.6lb)	13x32.5x27cm (5x13x11in)	12

## TECHNICAL DRAWINGS

The indicated measurements are expressed in millimetres.

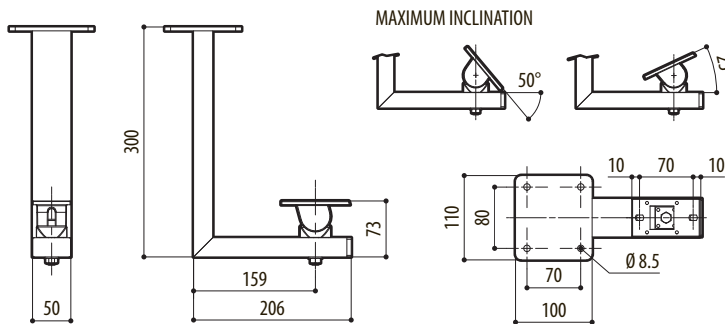

WCM3A