

WCM5A

CEILING MOUNT



DESCRIPTION

Bracket with external cable passage. Suitable for housings equipped with cable glands.

TECHNICAL DATA

MECHANICAL

Made of aluminium

Load rating: 15kg (33.5lb)

Length: 412mm (16.2in)

500mm (19in) linear extension available with WCPMA

Unit weight: 1.4kg (3lb)

PART NUMBER

WCM5A Ceiling bracket with ball joint

PACKAGE

Model Number	Weight	Dimensions (WxHxL)	Master carton
WCM5A	1.7kg (3.7lb)	10.5x37x37cm (4x14x14in)	6

TECHNICAL DRAWINGS

The indicated measurements are expressed in millimetres.

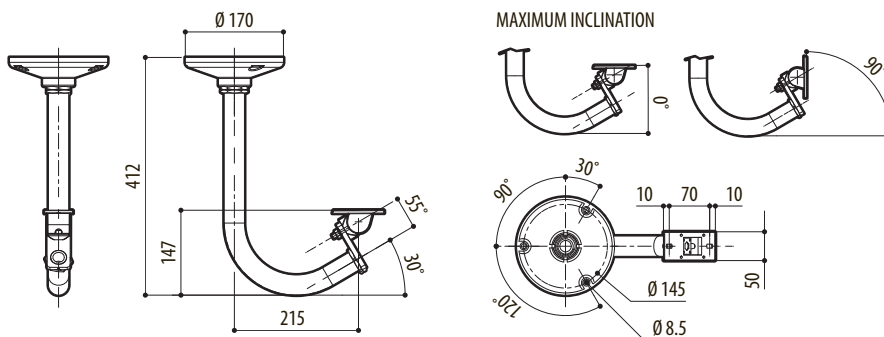

WCM5A