

NXM

CAMERA HOUSING FOR INSTALLATION IN AGGRESSIVE ENVIRONMENTS



IP66

IP67

IP68



NXM + VIPNX



NXM + VIPNX + NXPTH + NXFWBT + NXWBPTH1

DESCRIPTION

The NXM housing, entirely constructed from AISI 316L electropolished stainless steel, is designed to operate in specialist environments such as marine, industrial, chemical and where the external conditions are highly corrosive.

In order to prevent the formation of dust deposits, the housing can be equipped with a flange designed to create an air barrier in front of the glass.

The air, normally drawn from a compressor, can be purified by the optional filter group.

The options of wiper and water pump ensure a constant cleaning of the front window

The NXM housing can be installed on NXPTH Pan & Tilt head, to obtain a complete positioning system.

MAIN FEATURES

Made of AISI 316L electropolished stainless steel

IP66/IP67/IP68

Cylindrical body enclosed by two 9mm(0.4in)-thick circular flanges

2 PG13.5 cable glands in nickel-plated brass for external connections

Available accessories: heater and double heater (for temperatures down to -40°C (-40°F), camera power supply, air barrier + air filtering group and washer pump

Internal usable area (WxHxL, without accessories): 88x86x334mm (3.5x3.4x13.1in)

TECHNICAL DATA

MECHANICAL

Housing manufactured in polished stainless steel (austenitic stainless alloy steel resistant to corrosion and heat):

- AISI 316L
- UNI 6900-71: X 2 Cr Ni Mo 17 12 2
- DIN 17006: X 2 Cr Ni Mo 17 13 2
- N° werkstoff: 1.4404
- AFNOR: Z2 CND 17-12
- BSI: 316S11

The screws utilised are in austenitic alloy stainless steel, corrosion and heat resistant according to the following standards:

- ISO: 7380
- AISI: 316
- ISO quality: A4

Internal usable area (WxH): 88x86mm (3.5x3.4in)

Internal usable area with double heater (WxH): 55x100mm (2.2x3.9in)

Internal usable length (without accessories): 334mm (13.1in)

Internal usable length (with heater and/or power supply): 245mm (9.6in)

External dimensions: Ø 154mm, length 370mm (14.6in)

Flange thickness: 9mm (0.35in) (front/back)

Cable glands: 2xPG13.5 (nickel-plated brass for external connections)

Gaskets: High sealing O-ring

Housing window

- Material: Tempered extra clear glass
- Usable diameter: 97mm, 95mm (with air barrier)
- Thick: 4mm

Unit weight: 6kg (13.3lb)

ELECTRICAL

Supply voltage/Current consumption (version with heater, Ton 15°C±3°C (59°F±5°F), Toff 22°C±3°C (72°F±5°F)):

- 12Vdc, 1.6A max
- 24Vac, 0.85A max, 50/60Hz
- 120Vac, 0.35A max, 50/60Hz
- 230Vac, 0.18A max, 50/60Hz

Supply voltage/Current consumption (version with double heater, Ton 15°C±3°C (59°F±5°F), Toff 22°C±3°C (72°F±5°F)):

- 120Vac, 0.7A max, 50/60Hz
- 230Vac, 0.35A max, 50/60Hz

Camera power supply

- IN from 100Vac up to 240Vac, 50/60Hz - OUT 12Vdc, 1.25A
- IN 230Vac, 50Hz - OUT 24Vac, 50Hz, 400mA

ENVIRONMENT

For indoors and outdoors installation

Submersible: up to -50m (-164ft) (pressure: 5bar)

Operating temperature with heater: from -20°C (-4°F) up to +60°C (140°F)

Operating temperature with double heater: from -40°C (-40°F) up to +60°C (140°F)

Relative humidity: from 5% up to 95%

CERTIFICATIONS

Electrical safety (CE): EN60065

Electromagnetic compatibility (CE): EN50130-4, EN61000-6-3

IP protection degree (EN60529):

- IP66
- IP67
- IP68

EAC certification

ACCESSORIES

NXCTPG13SS	Kit of 2xPG 13.5 stainless steel cable glands IP68 for stainless steel housings.
OHEH06B	Heater 120/230Vac
OHEH05B	Heater 12Vdc/24Vac
ONXPS1B	Wide range power supply for camera IN 100-240Vac - OUT 12Vdc, 1.25A
ONXPS2B	Camera power supply IN 230Vac - OUT 24Vac, 400mA
VIPNX1C	230Vac stainless steel wiper for NXM housing
VIPNX2C	24Vac stainless steel wiper for NXM housing
ONXAB2	Front flange with air barrier and tempered glass
NXFIGRU	Filtering group for compressed air cleaning
WASOV5L5M00	Water tank 5l (1.3gal), pump with delivery up to 5m (16ft), IN 230Vac-24Vac-120Vac
WASOV23L5M00	Water tank 23l (6gal), pump with delivery up to 5m (16ft), IN 230Vac-24Vac-120Vac
WASOV23L11M00	Water tank 23l (6gal), pump with delivery up to 11m (36ft), IN 230Vac-24Vac-120Vac
WAS1V23L30M00	Water tank 23l (6gal), pump with delivery up to 30m (98ft) with water floating, IN 230Vac
WAS3V23L30M00	Water tank 23l (6gal), pump with delivery up to 30m (98ft) with water floating, IN 120Vac
WASPTOV5L5M00	Water tank 5l (1.3gal), pump with delivery up to 5m (16ft), IN 230Vac-24Vac-120Vac
WASPTOV23L5M00	Water tank 23l (6gal), pump with delivery up to 5m (16ft), IN 230Vac-24Vac-120Vac
WASPTOV23L11M00	Water tank 23l (6gal), pump with delivery up to 11m (36ft) with water floating, IN 230Vac-24Vac-120Vac
WASPT1V23L30M00	Water tank 23l (6gal), pump with delivery up to 30m (98ft) with water floating, IN 230Vac
WASPT3V23L30M00	Water tank 23l (6gal), pump with delivery up to 30m (98ft) with water floating, IN 120Vac
DTWRX	Data receiver for remote control of the wiper and WASPT range pumps in stand-alone housings
WASN1V10L20M00	Tank 10l (2.6gal) with integrated manual pump controlled by solenoid valve, delivery head up to 20m (66ft) max, IN 230Vac
WASN2V10L20M00	Tank 10l (2.6gal) with integrated manual pump controlled by solenoid valve, delivery head up to 20m (66ft) max, IN 24Vac
WASN3V10L20M00	Tank 10l (2.6gal) with integrated manual pump controlled by solenoid valve, delivery head up to 20m (66ft) max, IN 120Vac

BRACKETS AND ADAPTORS

NXWBS1	AISI 316L stainless steel wall bracket with joint
NXCOL	AISI 316L stainless steel pole adapter module
NXCW	AISI 316L stainless steel corner adapter module
NXWTU	Wall adaptor module in stainless steel AISI 316L
MHXWBS	AISI 316L stainless steel wall bracket
MHXWFCA	AISI 316L stainless steel ball joint

RELATED PRODUCTS

NXPTH	Stainless steel P&T motor
-------	---------------------------

SPARE PARTS

ONXMMAN	Maintenance kit for NXM
OSPAPVNXMC	Complete blade for VIPNX wiper

PACKAGE

Model Number	Weight	Dimensions (WxHxL)	Master carton
NXMOD1000B	7.3kg (16.1in)	29.5x19.5x49cm (11.6x7.7x3.8in)	3

AVAILABLE MODELS

Model Number	Sunshield	Heater 120Vac/230Vac	Heater 12Vdc/24Vac	Double heater 120/230Vac	Max consumption
NXMOD1000B	–	–	–	–	–
NXM1K1000B	✓	✓	–	–	40W
NXM2K1000B	✓	–	✓	–	20W
NXM1K1050	✓	–	–	✓	80W

TECHNICAL DRAWINGS

The indicated measurements are expressed in millimetres.

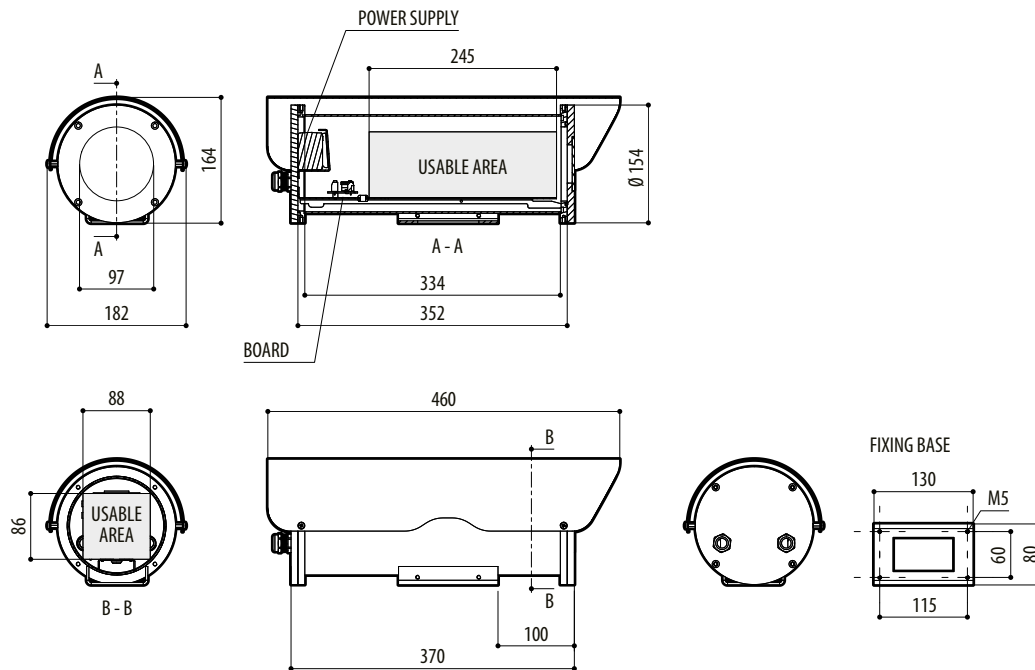

NXM