

STAINLESS STEEL HOUSINGS AND CAMERAS, BRACKETS



NXWBL

WALL BRACKET FOR NXL HOUSING

Made of AISI 316L electropolished stainless steel

Load rating: 45kg (99lb)

Length: 596mm (23.5in)

Can be coupled with modular components: NXCOL, NXCW



NXWBL

NXWBS1

WALL MOUNT BRACKET

Made of AISI 316L electropolished stainless steel

Load rating: 45kg (99lb)

Dimensions: 371x186mm (14.6x7.3in)

Suitable for: NXCOL, NXCW



NXWBS1

NXCOL

POLE MOUNT ADAPTOR

Made of AISI 316L electropolished stainless steel

For pole diameters: from 110mm (4.3in) up to 150mm (5.9in)

Load rating: 50kg (110lb)

Dimensions: 180x196mm (7.0x7.7in)



NXCOL

NXCW

CORNER MOUNT ADAPTOR

Made of AISI 316L electropolished stainless steel

Load rating: 50kg (110lb)

Dimensions: 180x291mm (7x11.5in)

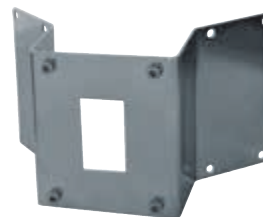

NXCW

NXWTU

ADAPTER MODULE FOR OBLIQUE SURFACES

Made of AISI 316L electropolished stainless steel

Load rating: 20kg (44lb) (static load)

Dimensions: 168x234mm (6.6x9.2in)

Suitable for: NXWBS1, WBOVA2, WBJA, WBMA

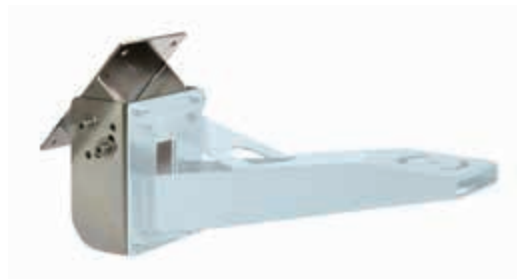

NXWTU

MHXWBS

WALL MOUNT BRACKET

Made of AISI 316L electropolished stainless steel

Load rating: 40kg (88lb)

Length: 440mm (17.3in)

Suitable for: MPXCW, MPXCOL



MHXWBS

MHXWFWCA

PARAPET MOUNTING BRACKET

Made of AISI 316L electropolished stainless steel

Load rating: 40kg (88lb)

Dimensions: Ø 101.6mm (4in)

Compatible with the bracket: NXFWBT

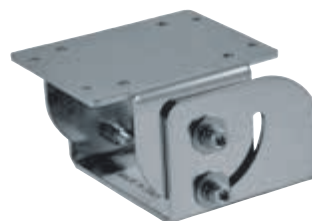

MHXWFWCA

TECHNICAL DATA

NXWBL

MECHANICAL

Bracket for NXL

Suitable for: NXCOL, NXCW

Made of AISI 316L electropolished stainless steel

Load rating: 45kg (99lb)

Length: 596mm (23.5in)

Unit weight: 5.5kg (12.1lb)

PART NUMBER

NXWBL AISI 316L stainless steel wall bracket with joint

PACKAGE

Model Number	Weight	Dimensions (WxHxL)	Master carton
NXWBL	5.6kg (12.3lb)	19x16x60cm (7.5x6.3x23.6in)	-

NXWBS1

MECHANICAL

Bracket for NTC, NXM36, NXM, NTM, NXW, NTW

Bracket for MVX, MVXT, MVXHD

Suitable for: NXCOL, NXCW

Made of AISI 316L electropolished stainless steel

Load rating: 45kg (99lb)

Dimensions: 371x186mm (14.6x7.3in)

Unit weight: 2.5kg (5.5lb)

PART NUMBER

NXWBS1 AISI 316L stainless steel wall bracket with joint

PACKAGE

Model Number	Weight	Dimensions (WxHxL)	Master carton
NXWBS1	2.8kg (6.2lb)	16x18.5x46cm (6.3x7.3x18.1in)	8

NXCOL

MECHANICAL

Suitable for NXWBS1, NXWBL, NXWBPTH1

Made of AISI 316L electropolished stainless steel

For pole diameters 110-150mm (4.3-5.9in)

Load rating: 50kg (110lb)

Unit weight: 3.3kg (7.3lb)

PART NUMBER

NXCOL AISI 316L stainless steel pole adapter module

PACKAGE

Model Number	Weight	Dimensions (WxHxL)	Master carton
NXCOL	3.5kg (7.7lb)	14x25.5x20cm (5.5x10x7.9in)	8

NXCW

MECHANICAL

Suitable for NXWBS1, NXWBL, NXWBPTH1

Made of AISI 316L electropolished stainless steel

Load rating: 50kg (110lb)

Dimensions: 180x291mm (7x11.5in)

Unit weight: 1.2kg (2.6lb)

PART NUMBER

NXCW AISI 316L stainless steel corner adapter module

PACKAGE

Model Number	Weight	Dimensions (WxHxL)	Master carton
NXCW	1.3kg (2.8lb)	24x32x24.5cm (9.4x12.6x9.6in)	5

NXWTU

MECHANICAL

Suitable for NXWBS1, WBOVA2, WBJA, WBMA brackets
Made of AISI 316L electropolished stainless steel
Load rating: 20kg (44lb) (static load)
Screws tightening torque: 20Nm
Dimensions: 168x234mm (6.6x9.2in)
Unit weight: 2.6kg (5.7lb)

PART NUMBER

NXWTU AISI 316L stainless steel adapter module for oblique surfaces

PACKAGE

Model Number	Weight	Dimensions (WxHxL)	Master carton
NXWTU	2.8kg (6.2lb)	24x15x21cm (9.4x6x8.2in)	10

MHXWBS

MECHANICAL

Bracket for MHX, MHXT, NXM, NXM36, NXM36 Hi-PoE, NXW, NTW, NTM
Suitable for MPXCOL, MPXCW
Made of AISI 316L electropolished stainless steel
Load rating: 40kg (88lb)
Length: 440mm (17.3in)
Unit weight: 5.4kg (11.9lb)

PART NUMBER

MHXWBS AISI 316L stainless steel wall bracket

PACKAGE

Model Number	Weight	Dimensions (WxHxL)	Master carton
MHXWBS	6.5kg (14.3lb)	58x34x22cm (23x13.4x8.7in)	-

MHXFWCA

MECHANICAL

Ball joint for housings: MVX, MVXT, MVXHD, MHX, MHXT, NXM, NXM36, NXM36 Hi-PoE, NXW, NTW, NTM
Suitable for: NXFWBT
Made of AISI 316L electropolished stainless steel
Load rating: 40kg (88lb)
Dimensions: Ø 101.6mm (4in)
Unit weight: 2kg (4.4lb)

PART NUMBER

MHXFWCA AISI 316L stainless steel ball joint

PACKAGE

Model Number	Weight	Dimensions (WxHxL)	Master carton
MHXFWCA	2.5kg (5.5lb)	19x19x19 cm (7.5x7.5x7.5in)	-

TECHNICAL DRAWINGS

The indicated measurements are expressed in millimetres.

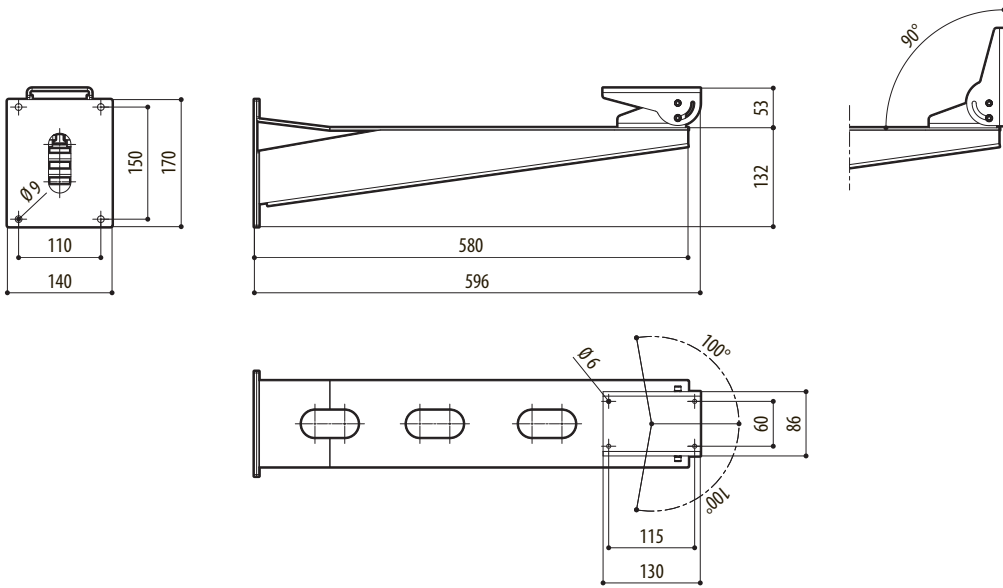

NXWBL

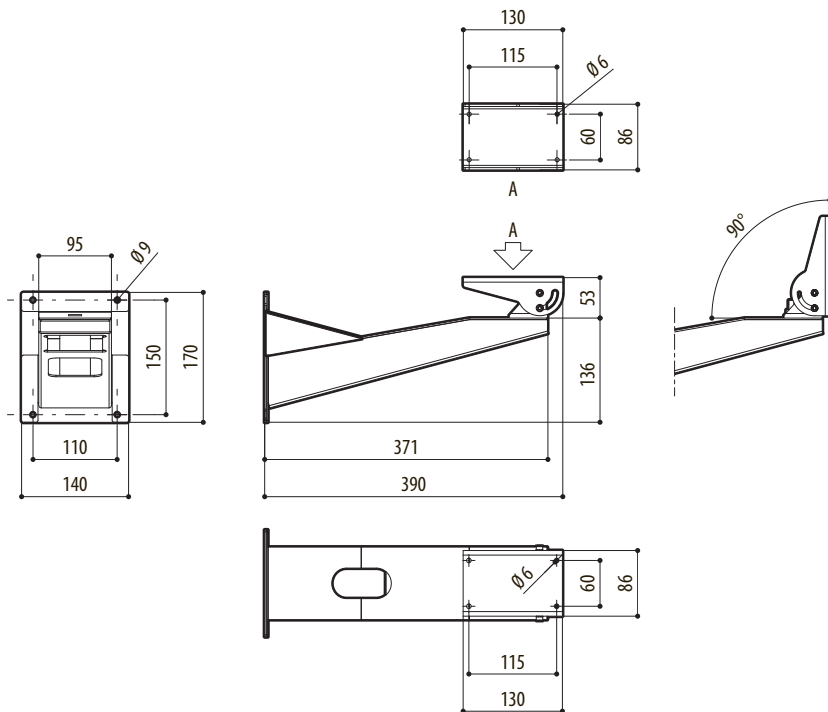

NXWBS1

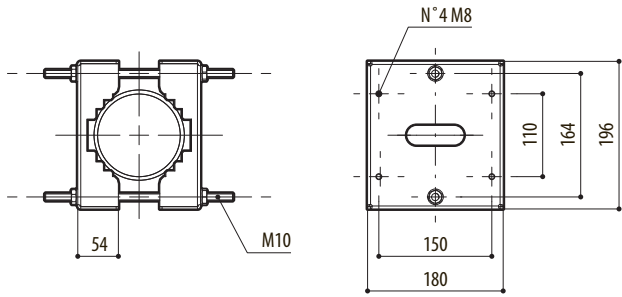

NXCOL

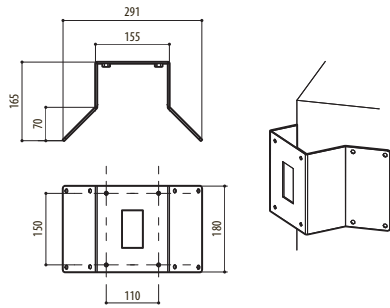

NXCW

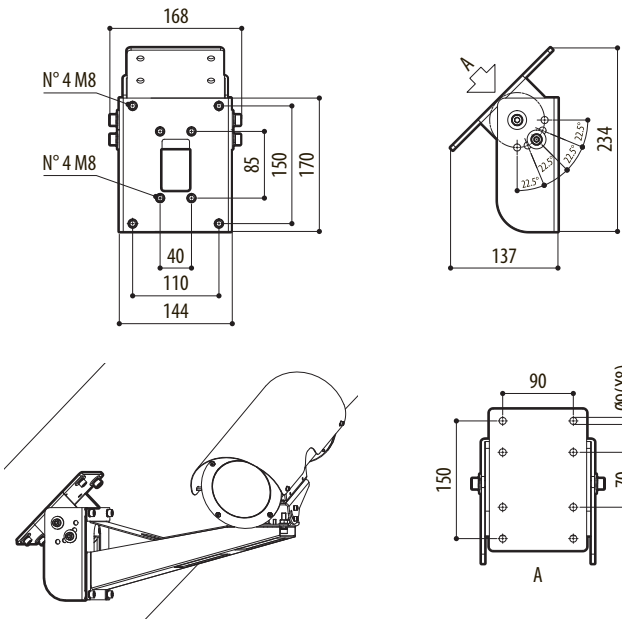

NXWTU

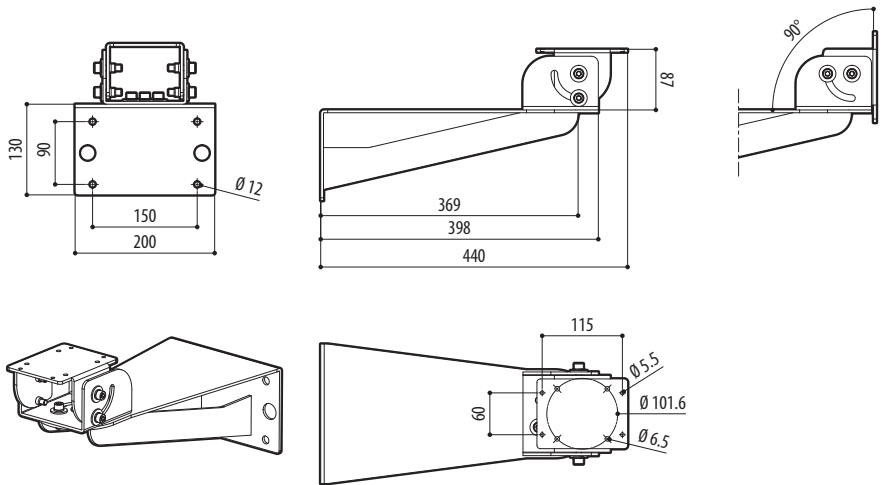

MHXWBS

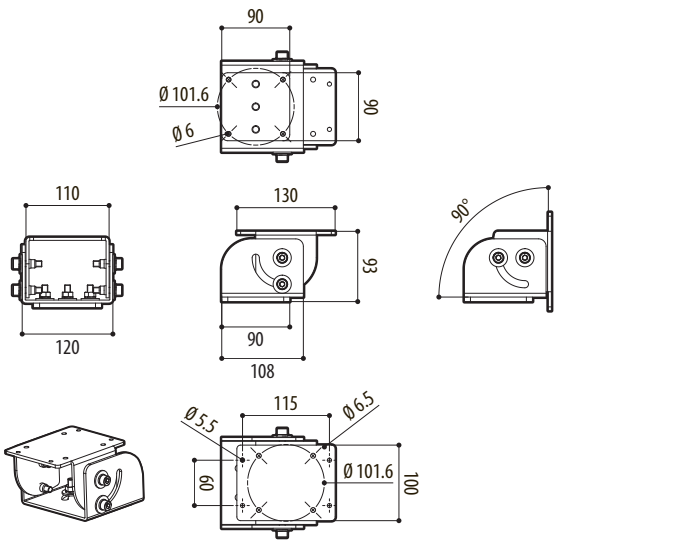

MHXWFWCA